

УДК 539.3

**LARGE RIGID-BODY MOTIONS AND STRAIN-DISPLACEMENT
RELATIONSHIPS OF THE LAYER-WISE SHELL THEORY**

G.M. Kulikov

Department of Applied Mathematics and Mechanics, TSTU

Key Words and Phrases: finite rotations; large rigid-body motions; layer-wise shell theory.

Abstract: It is considered the relationships for the Green-Lagrange strain tensor in curvilinear orthogonal coordinates exactly representing arbitrarily large rigid-body motions. This consideration is based on the kinematic Timoshenko hypothesis adopted for every layer of the shell (piece-wise linear approximation). As unknown functions $3(N+1)$ displacements of the face surfaces of layers are chosen, where N is a number of layers. The deduced relationships may be used in the finite element method for constructing new and efficient elements for multilayered shells.

1 Introduction

One of the main requirements of a finite element that is intended for the general non-linear analysis of shells is that it must lead to strain-free modes for large rigid-body motions. The adequate representation of large rigid-body motions is a necessary condition if a non-linear element is to have the good accuracy and convergence properties. Therefore, when an inconsistent non-linear shell theory is used to construct any finite element, erroneous straining modes under arbitrarily large rigid-body motions may be appeared. This problem has been only studied for the classical Kirchhoff-Love shell theory [1-3] and Timoshenko-Mindlin shell theory [4-8]. Herein, the more general study on the basis of the finite deformation layer-wise Timoshenko-Mindlin (LTM) shell theory taking into account the transverse normal deformation response is considered. As unknown functions $3(N+1)$ displacements of the face surfaces of layers are selected [9], where N is a number of layers. Such choice of unknowns allowed to deduce non-linear strain-displacement relationships of the LTM shell theory, which are completely free for arbitrarily large rigid-body motions.

2 Strain-displacement relationships of finite deformation elasticity theory

Let us consider a shell of the uniform thickness h . The shell may be defined as a three-dimensional body of volume V bounded by two bounding surfaces S^- and S^+ , located at the distances δ^- and δ^+ measured with respect to the reference surface S , and the edge boundary surface Ω that is perpendicular to the reference surface (Fig. 1). Let the reference surface S be referred to the orthogonal curvilinear coordinate system α_1 and α_2 , which coincides with the lines of principal curvatures of its surface; \mathbf{e}_1 and

\mathbf{e}_2 denote the tangent unit vectors to the lines of principal curvatures. The α_3 axis is oriented along the unit vector \mathbf{e}_3 normal to the reference surface.

The curvilinear components of the Green-Lagrange strain tensor for the finite deformation analysis can be written in a vector form as

$$2\varepsilon_{ij} = \frac{1}{H_i} \mathbf{u}_{,i} \left(\mathbf{e}_j + \frac{1}{2H_j} \mathbf{u}_{,j} \right) + \frac{1}{H_j} \mathbf{u}_{,j} \left(\mathbf{e}_i + \frac{1}{2H_i} \mathbf{u}_{,i} \right), \quad (1)$$

$$\mathbf{u} = \sum_i u_i \mathbf{e}_i, \quad H_\alpha = A_\alpha (1 + k_\alpha \alpha_3), \quad H_3 = 1,$$

where \mathbf{u} is the displacement vector; $u_i(\alpha_1, \alpha_2, \alpha_3)$ are the components of this vector, which are measured in accordance with the total Lagrangian formulation from the initial configuration (Fig. 1); A_α and k_α are the Lamé coefficients and principal curvatures of the reference surface; H_α are the Lamé coefficients of any surface parallel to the reference surface. Here and in the following developments the abbreviation $(\)_{,i}$ implies the partial derivative with respect to the coordinate α_i , and indices i, j take the values 1, 2 and 3 while Greek indices α, β, γ take the values 1 and 2.

An arbitrarily large rigid-body motion can be defined as

$$\mathbf{u}^R = \mathbf{\Delta} + (\mathbf{\Phi} - \mathbf{E}) \mathbf{R}, \quad (2)$$

$$\mathbf{\Delta} = \sum_i \Delta_i \mathbf{e}_i, \quad \mathbf{R} = \mathbf{r} + \alpha_3 \mathbf{e}_3,$$

where \mathbf{R} is the position vector of any point of the shell; $\mathbf{r}(\alpha_1, \alpha_2)$ is the position vector of any point of the reference surface; $\mathbf{\Delta}$ is the constant displacement (translation) vector; \mathbf{E} is the identity matrix; $\mathbf{\Phi}$ is the orthogonal rotation matrix defined as

$$\mathbf{\Phi} = \begin{bmatrix} \cos\theta\cos\psi & \cos\theta\sin\psi & -\sin\theta \\ -\cos\varphi\sin\psi + \sin\varphi\sin\theta\cos\psi & \cos\varphi\cos\psi + \sin\varphi\sin\theta\sin\psi & \sin\varphi\cos\theta \\ \sin\varphi\sin\psi + \cos\varphi\sin\theta\cos\psi & -\sin\varphi\cos\psi + \cos\varphi\sin\theta\sin\psi & \cos\varphi\cos\theta \end{bmatrix}, \quad (3)$$

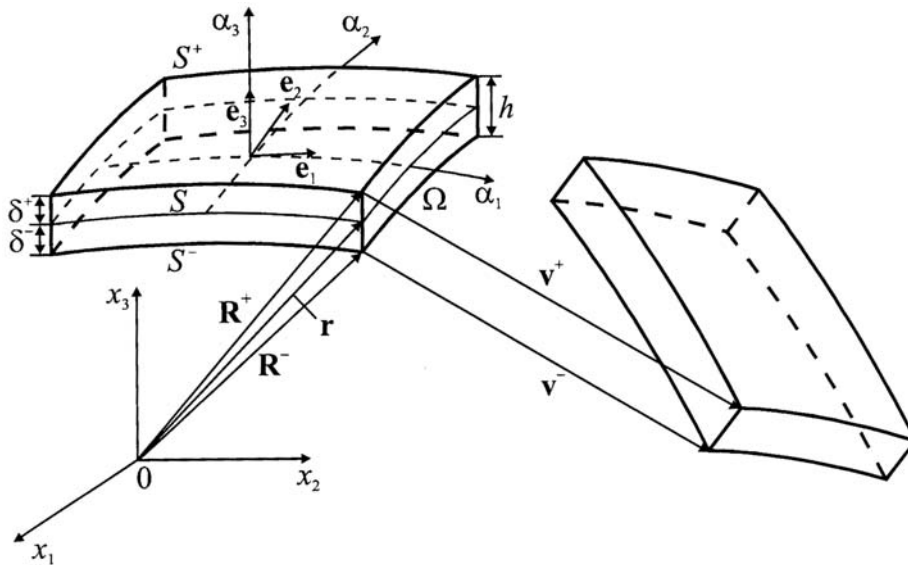

Fig. 1 Geometry and kinematics of the shell

where φ , θ and ψ are the modified Euler angles [10] that characterize a rotation of the shell around point O (Fig. 1).

The derivatives of the translation and position vectors with respect to the coordinate α_i can be written as

$$\mathbf{\Delta}_{,i} = \mathbf{0}, \quad \mathbf{R}_{,i} = H_i \mathbf{e}_i. \quad (4)$$

Taking into account (2)-(4), one obtains the following expression for derivatives:

$$\frac{1}{H_i} \mathbf{u}_{,i}^R = \mathbf{\Phi} \mathbf{e}_i - \mathbf{e}_i. \quad (5)$$

It can be verified by using (5) that curvilinear components of the Green-Lagrange strain tensor (1) are all zero in a general large rigid-body motion, i.e.,

$$2\varepsilon_{ij}^R = (\mathbf{\Phi} \mathbf{e}_i)(\mathbf{\Phi} \mathbf{e}_j) - \mathbf{e}_i \mathbf{e}_j = 0. \quad (6)$$

This conclusion is true because an orthogonal transformation retains the scalar product of the vectors.

3 Strain-displacement relationships of finite deformation LTM shell theory

Let us consider a shell built up in the general case by the arbitrary superposition across the wall thickness of N layers of uniform thickness h_k . The k th layer may be defined as a 3- D body of volume V_k bounded by two surfaces S_{k-1} and S_k , located at the distances δ_{k-1} and δ_k measured with respect to the reference surface S , and the edge boundary surface Ω_k (Fig. 2). It is assumed that the bounding surfaces S_{k-1} and S_k are continuous, sufficiently smooth and without any singularities. The constituent layers of the shell are supposed to be rigidly joined, so that no slip on contact surfaces and no

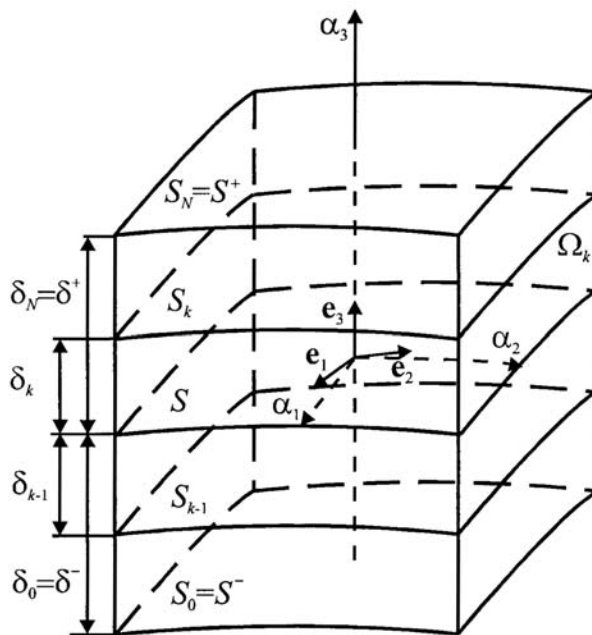

Fig. 2 Geometry of the multilayered shell

separation of layers can occur. Let the reference surface S be referred to an orthogonal curvilinear coordinate system α_1 and α_2 , which coincides with the lines of principal curvatures of its surface. The α_3 axis is oriented along the normal direction. Here and in the following developments index $k = \overline{1, N}$.

The finite deformation LTM shell theory is based on the linear approximation of the displacements in the thickness direction of the k th layer [9]

$$\mathbf{u}^{(k)} = N_k^-(\alpha_3) \mathbf{v}^{(k-1)} + N_k^+(\alpha_3) \mathbf{v}^{(k)}, \quad (7)$$

$$\mathbf{v}^{(\ell)} = \sum_i v_i^{(\ell)} \mathbf{e}_i, \quad N_k^-(\alpha_3) = \frac{1}{h_k}(\delta_k - \alpha_3), \quad N_k^+(\alpha_3) = \frac{1}{h_k}(\alpha_3 - \delta_{k-1}),$$

where $\mathbf{v}^{(\ell)}$ are the displacement vectors of the face surfaces of the layers; $v_i^{(\ell)}(\alpha_1, \alpha_2)$ are the components of these vectors; $N_k^\pm(\alpha_3)$ are the linear shape functions of the k th layer; $\ell = k-1, k$.

Substituting displacements (7) into the strain-displacement relationships (1) and taking into account formulas for the derivatives of the unit vector \mathbf{e}_3 with respect to the curvilinear coordinates [3]

$$\frac{1}{A_\alpha} \mathbf{e}_{3,\alpha} = k_\alpha \mathbf{e}_\alpha, \quad (8)$$

one may obtain the strain-displacement relationships of the finite deformation LTM theory of shells with thick layers

$$\begin{aligned} 2\varepsilon_{\alpha\beta}^{(k)a} = & \left[N_k^-(\alpha_3) \frac{1}{H_\alpha} \mathbf{v}_{,\alpha}^{(k-1)} + N_k^+(\alpha_3) \frac{1}{H_\alpha} \mathbf{v}_{,\alpha}^{(k)} \right] \mathbf{e}_\beta + \\ & + \left[N_k^-(\alpha_3) \frac{1}{H_\beta} \mathbf{v}_{,\beta}^{(k-1)} + N_k^+(\alpha_3) \frac{1}{H_\beta} \mathbf{v}_{,\beta}^{(k)} \right] \mathbf{e}_\alpha + \\ & + \left[N_k^-(\alpha_3) \frac{1}{H_\alpha} \mathbf{v}_{,\alpha}^{(k-1)} + N_k^+(\alpha_3) \frac{1}{H_\alpha} \mathbf{v}_{,\alpha}^{(k)} \right] \times \\ & \times \left[N_k^-(\alpha_3) \frac{1}{H_\beta} \mathbf{v}_{,\beta}^{(k-1)} + N_k^+(\alpha_3) \frac{1}{H_\beta} \mathbf{v}_{,\beta}^{(k)} \right], \end{aligned} \quad (9a)$$

$$2\varepsilon_{\alpha 3}^{(k)a} = \frac{\bar{H}_\alpha^{(k)}}{H_\alpha} \boldsymbol{\beta}^{(k)} \mathbf{e}_\alpha + \frac{1}{H_\alpha} \bar{\mathbf{v}}_{,\alpha}^{(k)} (\mathbf{e}_3 + \boldsymbol{\beta}^{(k)}) + (\alpha_3 - \bar{\delta}_k) \frac{1}{H_\alpha} \varepsilon_{33,\alpha}^{(k)a}, \quad (9b)$$

$$\varepsilon_{33}^{(k)a} = \boldsymbol{\beta}^{(k)} \left(\mathbf{e}_3 + \frac{1}{2} \boldsymbol{\beta}^{(k)} \right), \quad \boldsymbol{\beta}^{(k)} = \frac{1}{h_k} (\mathbf{v}^{(k)} - \mathbf{v}^{(k-1)}), \quad \bar{\mathbf{v}}^{(k)} = \frac{1}{2} (\mathbf{v}^{(k-1)} + \mathbf{v}^{(k)}), \quad (9c)$$

where $\bar{H}_\alpha^{(k)} = A_\alpha (1 + k_\alpha \bar{\delta}_k)$ are the Lamé coefficients of the middle surface of the k th layer; $\bar{\delta}_k = (\delta_{k-1} + \delta_k)/2$ is the distance from the reference surface to the middle surface of the k th layer.

Replacing further the Lamé coefficients H_α in (9a) by their values on the bottom and top surfaces of the k th layer $H_\alpha^{(k-1)} = A_\alpha (1 + k_\alpha \delta_{k-1})$ and $H_\alpha^{(k)} = A_\alpha (1 + k_\alpha \delta_k)$, and in (9b) by their values on the middle surface $\bar{H}_\alpha^{(k)}$ of the k th layer, the strain-

displacement relationships of the finite deformation LTM theory of shells with moderately thick layers are obtained

$$\begin{aligned}
 2\varepsilon_{\alpha\beta}^{(k)b} = & \left[N_k^-(\alpha_3) \frac{1}{H_\alpha^{(k-1)}} \mathbf{v}_{,\alpha}^{(k-1)} + N_k^+(\alpha_3) \frac{1}{H_\alpha^{(k)}} \mathbf{v}_{,\alpha}^{(k)} \right] \mathbf{e}_\beta + \\
 & + \left[N_k^-(\alpha_3) \frac{1}{H_\beta^{(k-1)}} \mathbf{v}_{,\beta}^{(k-1)} + N_k^+(\alpha_3) \frac{1}{H_\beta^{(k)}} \mathbf{v}_{,\beta}^{(k)} \right] \mathbf{e}_\alpha + \\
 & + \left[N_k^-(\alpha_3) \frac{1}{H_\alpha^{(k-1)}} \mathbf{v}_{,\alpha}^{(k-1)} + N_k^+(\alpha_3) \frac{1}{H_\alpha^{(k)}} \mathbf{v}_{,\alpha}^{(k)} \right] \times \\
 & \times \left[N_k^-(\alpha_3) \frac{1}{H_\beta^{(k-1)}} \mathbf{v}_{,\beta}^{(k-1)} + N_k^+(\alpha_3) \frac{1}{H_\beta^{(k)}} \mathbf{v}_{,\beta}^{(k)} \right], \quad (10a)
 \end{aligned}$$

$$2\varepsilon_{\alpha 3}^{(k)b} = \boldsymbol{\beta}^{(k)} \mathbf{e}_\alpha + \frac{1}{\bar{H}_\alpha^{(k)}} \bar{\mathbf{v}}_{,\alpha}^{(k)} (\mathbf{e}_3 + \boldsymbol{\beta}^{(k)}) + (\alpha_3 - \bar{\delta}_k) \frac{1}{\bar{H}_\alpha^{(k)}} \varepsilon_{33,\alpha}^{(k)b}, \quad (10b)$$

$$\varepsilon_{33}^{(k)b} = \boldsymbol{\beta}^{(k)} \left(\mathbf{e}_3 + \frac{1}{2} \boldsymbol{\beta}^{(k)} \right), \quad \boldsymbol{\beta}^{(k)} = \frac{1}{h_k} (\mathbf{v}^{(k)} - \mathbf{v}^{(k-1)}), \quad \bar{\mathbf{v}}^{(k)} = \frac{1}{2} (\mathbf{v}^{(k-1)} + \mathbf{v}^{(k)}). \quad (10c)$$

The strain-displacement relationships (10) are more convenient than (9) because they are completely free for arbitrarily large rigid-body motions. The proof of this fundamental fact follows from formulas for large rigid-body motions of the k th layer and their derivatives with respect to the curvilinear coordinates

$$\mathbf{v}^{(\ell)R} = \boldsymbol{\Delta} + (\boldsymbol{\Phi} - \mathbf{E}) \mathbf{R}^{(\ell)}, \quad (11)$$

$$\frac{1}{H_\alpha^{(\ell)}} \mathbf{v}_{,\alpha}^{(\ell)R} = \boldsymbol{\Phi} \mathbf{e}_\alpha - \mathbf{e}_\alpha, \quad (12)$$

where $\mathbf{R}^{(\ell)} = \mathbf{r} + \delta_\ell \mathbf{e}_3$ are the position vectors of points of the bottom S_{k-1} and top S_k surfaces of the k th layer and $\ell = k-1, k$. It can be verified by using (11), (12) and the above property of the orthogonal transformation (3) that curvilinear components of the Green-Lagrange strain tensor (10) are all zero in an arbitrarily large rigid-body motion:

$$2\varepsilon_{\alpha\beta}^{(k)bR} = (\boldsymbol{\Phi} \mathbf{e}_\alpha)(\boldsymbol{\Phi} \mathbf{e}_\beta) - \mathbf{e}_\alpha \mathbf{e}_\beta = 0, \quad 2\varepsilon_{\alpha 3}^{(k)bR} = \frac{H_\alpha}{\bar{H}_\alpha^{(k)}} [(\boldsymbol{\Phi} \mathbf{e}_\alpha)(\boldsymbol{\Phi} \mathbf{e}_3) - \mathbf{e}_\alpha \mathbf{e}_3] = 0,$$

$$2\varepsilon_{33}^{(k)bR} = (\boldsymbol{\Phi} \mathbf{e}_3)(\boldsymbol{\Phi} \mathbf{e}_3) - \mathbf{e}_3 \mathbf{e}_3 = 0.$$

It should be mentioned that tangential strains $\varepsilon_{\alpha\beta}^{(k)b}$ are distributed over the layer thickness according to the quadratic law. Taking into account that each layer of the shell is thin, this complication of the LTM shell theory would be unreasonable because of the minor significance of the quadratic terms in most engineering problems. Therefore, more attractive strain-displacement relationships of the finite deformation LTM theory of shells with thin layers can be written as

$$2\varepsilon_{\alpha\beta}^{(k)c} = N_k^-(\alpha_3) \left(\frac{1}{H_\alpha^{(k-1)}} \mathbf{v}_{,\alpha}^{(k-1)} \mathbf{e}_\beta + \frac{1}{H_\beta^{(k-1)}} \mathbf{v}_{,\beta}^{(k-1)} \mathbf{e}_\alpha + \frac{1}{H_\alpha^{(k-1)} H_\beta^{(k-1)}} \mathbf{v}_{,\alpha}^{(k-1)} \mathbf{v}_{,\beta}^{(k-1)} \right) + N_k^+(\alpha_3) \left(\frac{1}{H_\alpha^{(k)}} \mathbf{v}_{,\alpha}^{(k)} \mathbf{e}_\beta + \frac{1}{H_\beta^{(k)}} \mathbf{v}_{,\beta}^{(k)} \mathbf{e}_\alpha + \frac{1}{H_\alpha^{(k)} H_\beta^{(k)}} \mathbf{v}_{,\alpha}^{(k)} \mathbf{v}_{,\beta}^{(k)} \right), \quad (13a)$$

$$2\varepsilon_{\alpha 3}^{(k)c} = \boldsymbol{\beta}^{(k)} \mathbf{e}_\alpha + \frac{1}{\bar{H}_\alpha^{(k)}} \bar{\mathbf{v}}_{,\alpha}^{(k)} (\mathbf{e}_3 + \boldsymbol{\beta}^{(k)}) + (\alpha_3 - \bar{\delta}_k) \frac{1}{\bar{H}_\alpha^{(k)}} \varepsilon_{33,\alpha}^{(k)c}, \quad (13b)$$

$$\varepsilon_{33}^{(k)c} = \boldsymbol{\beta}^{(k)} \left(\mathbf{e}_3 + \frac{1}{2} \boldsymbol{\beta}^{(k)} \right), \quad \boldsymbol{\beta}^{(k)} = \frac{1}{h_k} (\mathbf{v}^{(k)} - \mathbf{v}^{(k-1)}), \quad \bar{\mathbf{v}}^{(k)} = \frac{1}{2} (\mathbf{v}^{(k-1)} + \mathbf{v}^{(k)}). \quad (13c)$$

These strain-displacement relationships are also invariant under all large rigid-body motions because

$$\varepsilon_{ij}^{(k)cR} = 0.$$

It is apparent that deduced strain-displacement relationships (9), (10) and (13) satisfy the following coupling conditions:

$$\varepsilon_{\alpha\beta}^{(k)a} (\delta_\ell) = \varepsilon_{\alpha\beta}^{(k)b} (\delta_\ell) = \varepsilon_{\alpha\beta}^{(k)c} (\delta_\ell) = E_{\alpha\beta}^{(\ell)},$$

$$\varepsilon_{\alpha 3}^{(k)a} (\bar{\delta}_k) = \varepsilon_{\alpha 3}^{(k)b} (\bar{\delta}_k) = \varepsilon_{\alpha 3}^{(k)c} (\bar{\delta}_k) = \bar{E}_{\alpha 3}^{(k)},$$

where $E_{\alpha\beta}^{(\ell)}$ are the tangential strains of the face surfaces of layers; $\bar{E}_{\alpha 3}^{(k)}$ are the transverse shear strains of the middle surface of the k th layer and $\ell = k-1, k$. This statement is illustrated in Fig. 3.

Finally, we represent in a scalar form the strain-displacement relationships (13) that have a great importance for the finite element method

$$\varepsilon_{\alpha\beta}^{(k)c} = N_k^-(\alpha_3) E_{\alpha\beta}^{(k-1)} + N_k^+(\alpha_3) E_{\alpha\beta}^{(k)}, \quad \varepsilon_{\alpha 3}^{(k)c} = N_k^-(\alpha_3) E_{\alpha 3}^{(k)-} + N_k^+(\alpha_3) E_{\alpha 3}^{(k)+}, \quad (14)$$

$$\varepsilon_{33}^{(k)c} = E_{33}^{(k)} = e_{33}^{(k)} + \eta_{33}^{(k)},$$

where

$$E_{\alpha\beta}^{(\ell)} = e_{\alpha\beta}^{(\ell)} + \eta_{\alpha\beta}^{(\ell)}, \quad E_{\alpha 3}^{(k)\pm} = e_{\alpha 3}^{(k)\pm} + \eta_{\alpha 3}^{(k)\pm}, \quad (15)$$

$$e_{\alpha\alpha}^{(\ell)} = \frac{1}{\zeta_\alpha^{(\ell)}} \lambda_\alpha^{(\ell)}, \quad 2e_{12}^{(\ell)} = \frac{1}{\zeta_1^{(\ell)}} \omega_1^{(\ell)} + \frac{1}{\zeta_2^{(\ell)}} \omega_2^{(\ell)},$$

$$2e_{\alpha 3}^{(k)-} = \left(1 - \frac{k_\alpha h_k}{2\bar{\zeta}_\alpha^{(k)}} \right) \beta_\alpha^{(k)} - \frac{1}{\bar{\zeta}_\alpha^{(k)}} \theta_\alpha^{(k-1)}, \quad 2e_{\alpha 3}^{(k)+} = \left(1 + \frac{k_\alpha h_k}{2\bar{\zeta}_\alpha^{(k)}} \right) \beta_\alpha^{(k)} - \frac{1}{\bar{\zeta}_\alpha^{(k)}} \theta_\alpha^{(k)},$$

$$e_{33}^{(k)} = \beta_3^{(k)},$$

$$\eta_{\alpha\alpha}^{(\ell)} = \frac{1}{2(\zeta_\alpha^{(\ell)})^2} \left[(\lambda_\alpha^{(\ell)})^2 + (\omega_\alpha^{(\ell)})^2 + (\theta_\alpha^{(\ell)})^2 \right],$$

$$2\eta_{12}^{(\ell)} = \frac{1}{\zeta_1^{(\ell)} \zeta_2^{(\ell)}} (\lambda_1^{(\ell)} \omega_2^{(\ell)} + \lambda_2^{(\ell)} \omega_1^{(\ell)} + \theta_1^{(\ell)} \theta_2^{(\ell)}),$$

$$2\eta_{\alpha 3}^{(k)-} = \frac{1}{\bar{\zeta}_{\alpha}^{(k)}} \left(\beta_{\alpha}^{(k)} \lambda_{\alpha}^{(k-1)} + \beta_{\gamma}^{(k)} \omega_{\alpha}^{(k-1)} - \beta_3^{(k)} \theta_{\alpha}^{(k-1)} \right),$$

$$2\eta_{\alpha 3}^{(k)+} = \frac{1}{\bar{\zeta}_{\alpha}^{(k)}} \left(\beta_{\alpha}^{(k)} \lambda_{\alpha}^{(k)} + \beta_{\gamma}^{(k)} \omega_{\alpha}^{(k)} - \beta_3^{(k)} \theta_{\alpha}^{(k)} \right),$$

$$\eta_{33}^{(k)} = \frac{1}{2} \left[\left(\beta_1^{(k)} \right)^2 + \left(\beta_2^{(k)} \right)^2 + \left(\beta_3^{(k)} \right)^2 \right],$$

$$\lambda_{\alpha}^{(\ell)} = \frac{1}{A_{\alpha}} v_{\alpha, \alpha}^{(\ell)} + B_{\gamma} v_{\gamma}^{(\ell)} + k_{\alpha} v_3^{(\ell)}, \quad \omega_{\alpha}^{(\ell)} = \frac{1}{A_{\alpha}} v_{\gamma, \alpha}^{(\ell)} - B_{\gamma} v_{\alpha}^{(\ell)},$$

$$\theta_{\alpha}^{(\ell)} = -\frac{1}{A_{\alpha}} v_{3, \alpha}^{(\ell)} + k_{\alpha} v_{\alpha}^{(\ell)}, \quad \beta_i^{(k)} = \frac{1}{h_k} \left(v_i^{(k)} - v_i^{(k-1)} \right),$$

$$\zeta_{\alpha}^{(\ell)} = 1 + k_{\alpha} \delta_{\ell}, \quad \bar{\zeta}_{\alpha}^{(k)} = 1 + k_{\alpha} \bar{\delta}_k, \quad B_{\alpha} = \frac{1}{A_1 A_2} A_{\gamma, \alpha} \quad (\gamma \neq \alpha; \ell = k-1, k).$$

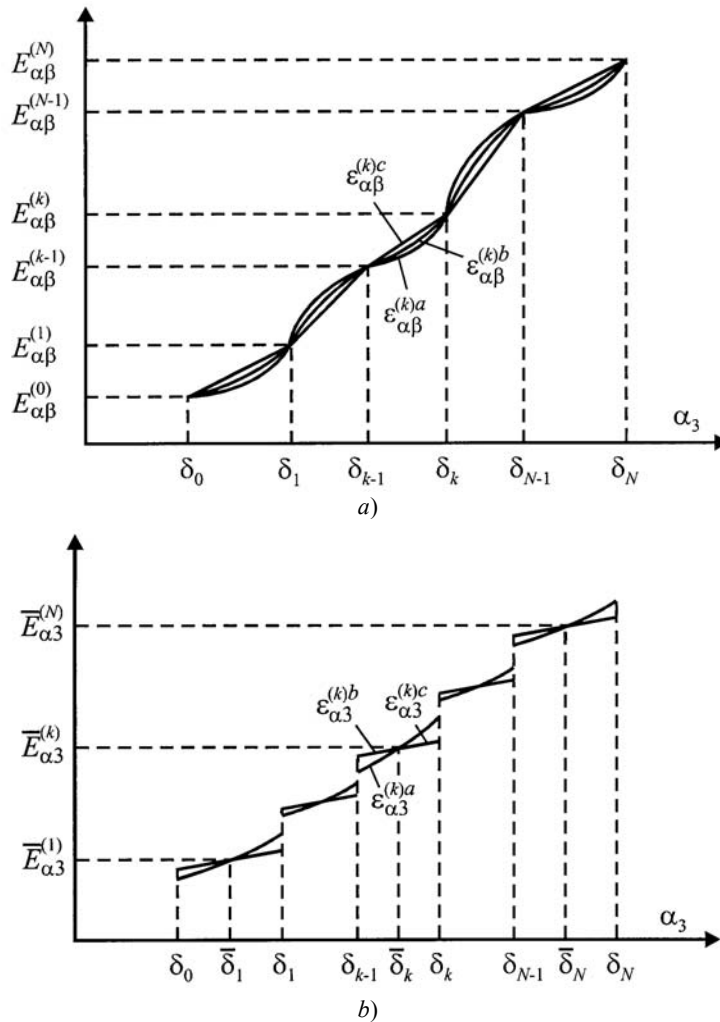

Fig. 3 Distribution of tangential (a) and transverse shear (b) strains over the shell thickness

4 Conclusions

Principally new strain-displacement relationships (14), (15) of the finite deformation LTM shell theory are developed. These strain-displacement relationships are very attractive because they are objective, i.e., invariant under all large rigid-body motions. So, they can be used for the formulation of the efficient curved finite elements in local curvilinear coordinates for the multilayered shells undergoing finite deformations.

References

1. Cantin G. Strain displacement relationships for cylindrical shells // AIAA Journal. – 1968. – Vol. 6. – Pp. 1787-1788.
2. Dawe D.J. Rigid-body motions and strain-displacement equations of curved shell finite elements // Int. J. Mech. Science. – 1972. – Vol. 14. – Pp. 569-578.
3. Gol'denveiser A.L. Theory of elastic thin shells. – Pergamon Press, Oxford, 1961.
4. Kulikov G.M., Plotnikova S.V. Finite element formulation of straight composite beams undergoing finite rotations // Trans. Tambov State Tech. Univ. – 2001. – Vol. 7, No. 4. – Pp. 617-633.
5. Kulikov G.M., Plotnikova S.V. Efficient mixed Timoshenko-Mindlin shell elements // Int. J. Numer. Methods Engrg. – 2002. – Vol. 55, No. 10. – Pp. 1167-1183.
6. Kulikov G.M., Plotnikova S.V. Simple and effective elements based upon Timoshenko-Mindlin shell theory // Comp. Methods Appl. Mech. Engrg. – 2002. – Vol. 191, No. 11-12. – Pp. 1173-1187.
7. Kulikov G.M., Plotnikova S.V. Non-linear strain-displacement equations exactly representing large rigid body motions. Part I. Timoshenko-Mindlin shell theory // Comp. Methods Appl. Mech. Engrg. – 2003. – Vol. 192, No. 7-8. – Pp. 851-875.
8. Kulikov G.M., Plotnikova S.V. Finite deformation plate theory and large rigid body motions // Int. J. Non-Linear Mech. – 2004. – Vol. 39, No. 7. – Pp. 1093-1109.
9. Kulikov G.M. Non-linear analysis of multilayered shells under initial stress // Int. J. Non-Linear Mech. – 2001. – Vol. 36, No. 2. – Pp. 323-334.
10. Washizu K. Variational methods in elasticity and plasticity, 3rd edition. – Pergamon Press, Oxford, 1982.

Большие перемещения оболочки как твердого тела и деформационные соотношения многослойных оболочек

Г.М. Куликов

Кафедра «Прикладная математика и механика», ТГТУ

Ключевые слова и фразы: большие перемещения твердого тела; конечные повороты; многослойная оболочка.

Аннотация: Получены соотношения для тензора деформаций Грина-Лагранжа в криволинейных ортогональных координатах, точно представляющие произвольно большие перемещения оболочки как жесткого тела, на основе кинематической гипотезы Тимошенко, принятой для каждого слоя (гипотеза ломаной линии). В качестве искомого функций выбраны $3(N+1)$ перемещений лицевых поверхностей слоев, где N – число слоев. Выведенные соотношения могут быть с успехом использованы в методе конечных элементов при построении новых и эффективных элементов многослойных оболочек.

Große Hüllenbewegungen als Hartkörper und Deformationskorrelationen der vielschichtigen Hüllen

Zusammenfassung: Es sind die Korrelationen für den Deformationstensor von Grin-Lagrange in den krummlinigen orthogonalen Koordinaten erhalten. Sie zeigen absichtlich große Hüllenbewegungen als Hartkörper auf Grund der für jede Schicht üblichen kinematischen Hypothese von Timoschenko (Hypothese der gebrochenen Linie). Als gesuchte Funktionen sind $3(N + 1)$ der Bewegungen von Außenseiten der Schichten gewählt, wo N die Zahl der Schichten ist. Die erhaltene Korrelationen können in der Methode der Endelemente beim Aufbau von neuen und effektiven endlichen Elementen der vielschichtigen Hüllen erfolgreich benutzt werden.

Grands transferts de l'enveloppe comme un corps solide et rapport de déformation des enveloppes à plusieurs couches

Résumé: Sont reçus les rapports pour le tenseur de déformation de Grin-Lagrange dans les coordonnées orthogonales curvilignes représentant exactement les transferts arbitrairement grands de l'enveloppe du corps rigide à la base de l'hypothèse cinématique de Timochenko prise pour chaque couche (hypothèse de la ligne brisée). En qualité des fonctions recherchées on a choisi les $3(N + 1)$ transferts des surfaces des couches où N est le nombre des couches. Les rapports reçus peuvent être utilisés avec succès dans la méthode des éléments finis pour la construction de nouveaux éléments finis efficaces des enveloppes à plusieurs couches.
